

# Specification

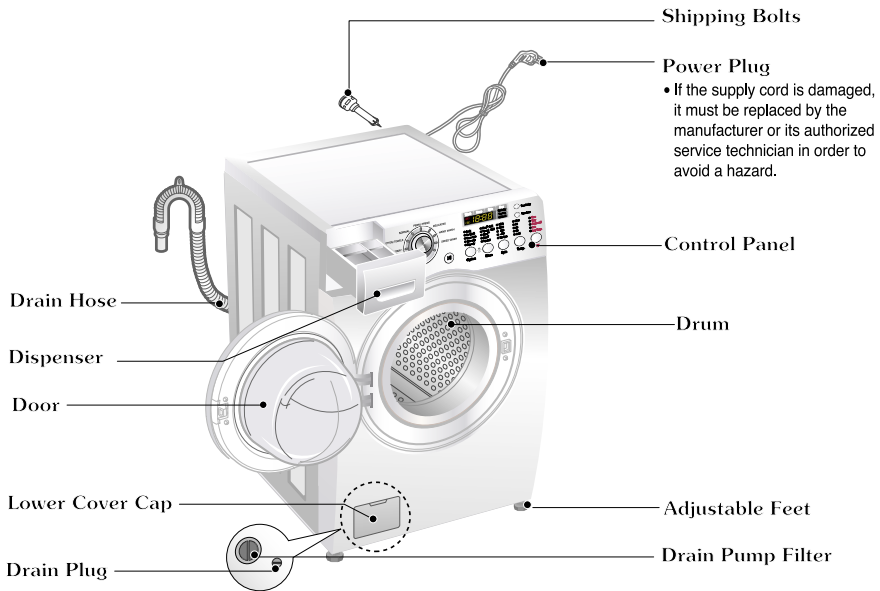

- Name: Front-loading Washing Machine
- Power supply : 120V~, 60Hz
- Size: 23<sup>3</sup>/<sub>8</sub> X 25<sup>3</sup>/<sub>8</sub> X 33<sup>1</sup>/<sub>4</sub> (inches)  
595 X 645 X 845 (mm)
- Weight: 147 lbs. (66.7 kg)
- Wash capacity: 2.11 cu.ft.
- Dry capacity: 2.11 cu.ft. – Max. 8<sup>13</sup>/<sub>16</sub>lbs. (4 kg)
- Spin speed: 1400 rpm max. (WM3431H\*)  
1200 rpm max. (WM3434H\*)
- Permissible water pressure: 4.5 ~ 145 PSI (30 ~ 1000 kPa)

\* Specifications subject to change by manufacturer.

## Accessories

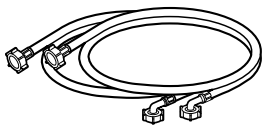

Hose  
Hot/Cold (1 each)



Wrench



Tie strap  
to secure drain hose to standpipe,  
inlet hose, or laundry tub

# Installation

Install or store unit where it will not be exposed to temperatures below freezing or exposed to outside weather conditions.

Properly ground washer to conform with all governing codes and ordinances.

To reduce the risk of electric shock, do not install the washer in humid spaces.

The base opening must not be obstructed by carpeting when the washing machine is installed on a carpeted floor.

In countries where there are areas which may be subject to infestation by cockroaches or other vermin, pay particular attention to keeping the appliance and its surroundings in clean condition at all times.

Damage caused by cockroaches or other vermin will not be covered by the appliance warranty.

## ■ Shipping bolts

The appliance is fitted with shipping bolts to prevent internal damage during transport.

- Packing and all shipping bolts must be removed before using the washer.
- When unpacking the base, be sure to remove the additional packing support in the middle of the base packing.

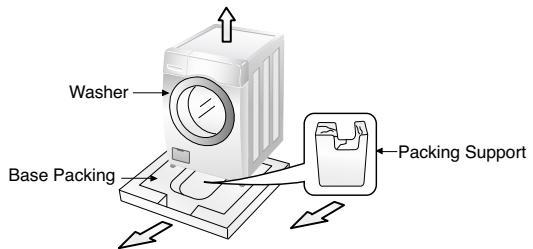

## ■ Removing shipping bolts

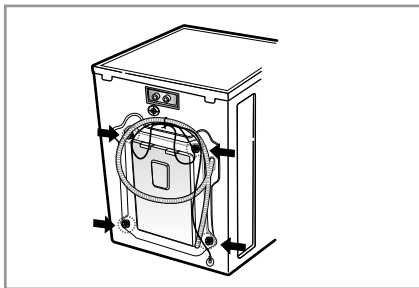

1. To prevent internal damage during transport, 4 locking bolts are installed. Before operating the washer, remove the bolts.

- If they are not removed, it may cause severe vibration, noise, and malfunction.

2. Unscrew the 4 bolts with the wrench supplied.

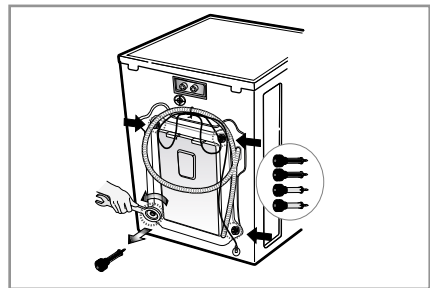

3. Take out the 4 bolts by twisting the braces slightly. Keep the 4 bolts and the wrench for future use.

- Whenever the appliance is transported, the shipping bolts must be replaced.

4. Close the holes with the caps supplied.

# I nstallation

## ■ Installation place requirement

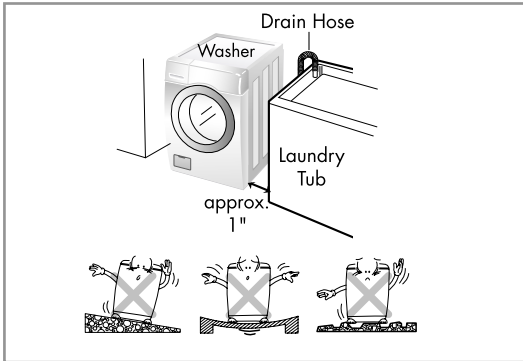

### Level floor

Allowable slope under entire washer is 1°.

### Power outlet

Must be within 60 inches (1.5 m) of either side of the washer. Do not overload the outlet with more than one appliance.

Time-delay fuse or circuit breaker is recommended.

**NOTE** It is the personal responsibility and obligation of the customer to have a proper outlet installed by a qualified electrician.

### Minimum installation spacing

- Additional spacing of 1 in. (2.5 cm) on all sides of the washer is recommended to reduce noise transfer.
- Most installations require a minimum 4 in. (10 cm) clearance behind the washer.
- Companion appliance spacing should also be considered.

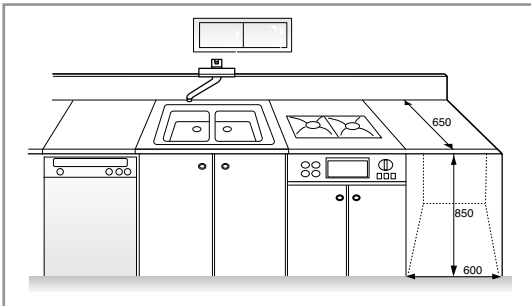

## ■ Positioning

- To minimize noise and vibration, the washer **MUST** be installed on a solidly constructed floor.
- Carpeting and soft tile surfaces are not recommended.
- Never install the washer on a platform or weakly supported structure.

**NOTE** A firm, solid floor is even more critical to a front-loading washer than to a top-loader. If your floor is wood and/or frame construction, you may need to reinforce it. Front-loaders use substantially faster spin speeds than top-loaders, causing greater vibration. If the floor is not solid, your washer will vibrate. You will hear and feel the vibration throughout your house.

# Installation

## ■ Electrical connection

- Do not use an extension cord or double adapter.
- If the supply cord is damaged, it must be replaced by a qualified person in order to avoid a hazard.
- If the machine will not be used for an extended time, unplug it and shut off the water supply.
- Connect the machine to a grounded outlet in accordance with current wiring regulations.
- The appliance must be positioned so that the plug is easily accessible.
- Repairs to the washing machine must only be carried out by qualified personnel. Repairs carried out by inexperienced persons may cause injury or serious malfunctioning. Contact your local service center.
- Do not install your washing machine in rooms where temperatures below freezing may occur. Frozen hoses may burst under pressure. The reliability of the electronic control unit may be impaired at temperatures below freezing point.
- If the appliance is delivered in the winter months and temperatures are below freezing : Store the washing machine at room temperature for a few hours before putting it into operation.

## ■ Washing Machine is to be connected to the water mains using new hoses Old hoses should not be used.

## ■ Connecting water supply hose

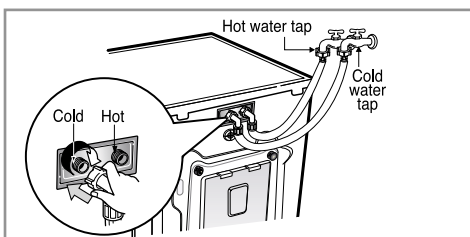
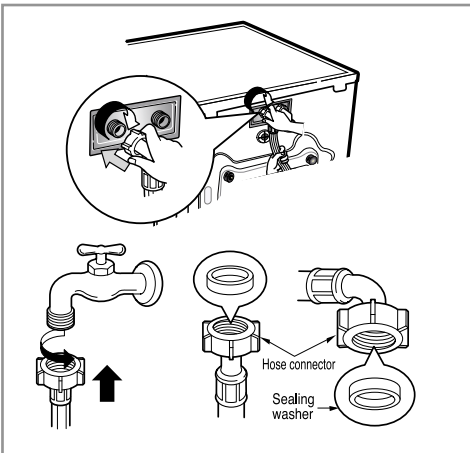

- Water supply pressure must be between 4.5 and 145 PSI (30~1000 kPa)
- Do not cross-thread when connecting inlet hose to the valve.
- If the water supply pressure is more than 145 PSI, a pressure reducing device should be installed.
- Two Sealing washers are supplied with the water inlet hoses to prevent water leaks.
- Check for leakage of washing machine connections by turning the tap completely on.
- Periodically check the condition of the hose and replace the hose if necessary.
- Make sure that there is no kink in the hose and that it is not crushed.
- Be sure that the two water input ports are connected to the correct water faucets. The connector for hot water is colored red.

# Installation

## ■ Installation of drain hose

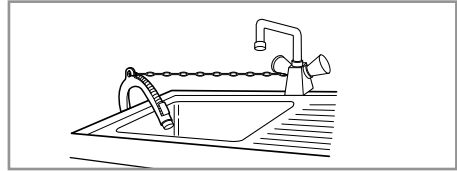
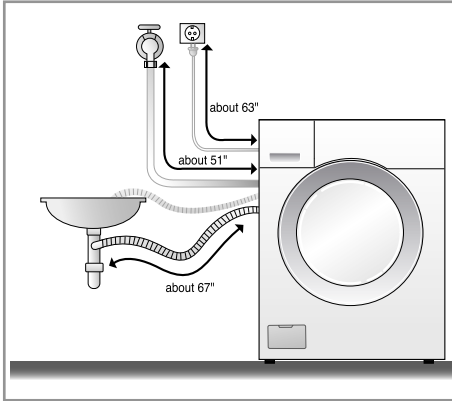

- When installing the drain hose at a sink, secure it so it cannot break away and cause flooding and damage.
- Properly securing the drain hose will protect the floor from damage due to water leakage.

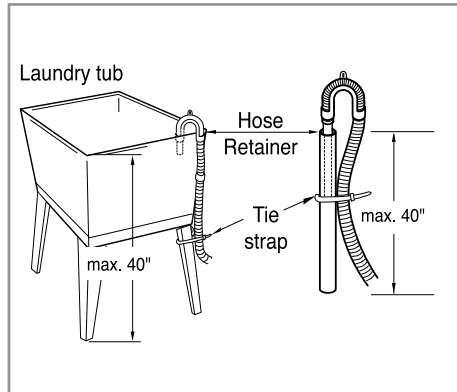
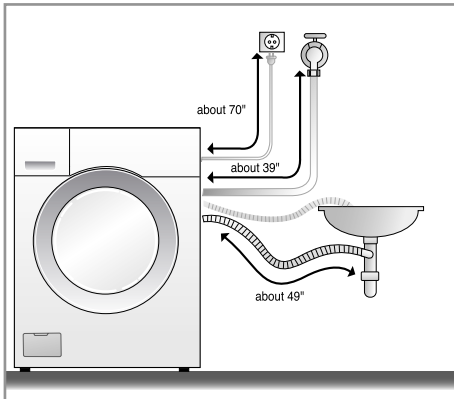

- The drain hose should not be placed higher than 40" above the floor.
- Properly securing the drain hose will protect the floor from damage due to water leakage.

**This equipment is not designed for maritime use or for mobile installations such as in RV's, aircraft, etc.**

**Turn off the faucet if the machine is to be left for an extended period of time (e.g. holiday).**

**When disposing of the appliance, cut off the power cable, and destroy the plug.**

**Disable the door lock to prevent young children being trapped inside.**

**Packaging material (e.g. Films, Styrofoam) can be dangerous for children. There is a risk of suffocation! Keep all packaging from children.**

# Installation

## ■ Level adjustment

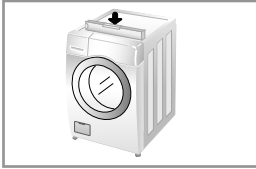

1. Adjusting the washing machine level properly prevents excessive noise and vibration.  
Install the appliance on a solid and level floor surface, preferably in a corner of the room.

**NOTE** Timber or suspended type flooring may contribute to excessive vibration and unbalance errors.

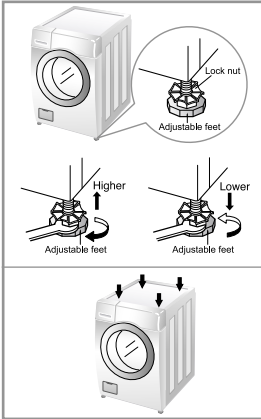

2. If the floor is uneven, adjust the adjustable feet as required. (do not insert pieces of wood etc. under the feet)

Make sure that all four feet are stable and resting on the floor and then check that the appliance is perfectly level. (use a spirit level)

**\* After the washer is level, tighten the lock nuts up towards the base of the washer. All lock nuts must be tightened.**

### \* Diagonal Check

*When pushing down the edges of the washing machine top plate diagonally, the machine should not move up and down at all. (Please, check both of two directions)*

*If machine rocks when pushing the machine top plate diagonally, adjust the feet again.*

## ■ Concrete floors

- The installation surface must be clean, dry and level.
- Install washer on a flat hard floor.

## ■ Tile floors (Slippery floors)

- Position each foot on the Tread Mat and level the machine to suit (Cut the Tread Mat into 2 3/4 inches squares and stick the pieces to the dry tile where machine is to be placed).
- \* Tread Mat is a self adhesive material used on ladders & steps to prevent slipping.**

## ■ Wooden floors

- Wooden floors are particularly susceptible to vibration.
- To prevent vibration we recommend you place rubber cups under each foot, at least 15mm thick under the washer, secured to at least 2 floor beams with screws.
- If possible install the washer in one of the corners of the room, where the floor is more stable.

**\* Insert the rubber cups to reduce vibration.**

**\* You can obtain the rubber cups (p/no.4620ER4002B) from the LG parts dept.**

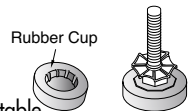

### Important!

- Proper placement and levelling of the washer ensure long, regular and reliable operation.
- The washer must be absolutely horizontal and stand firmly in position.
- It must not "Seesaw" across corners under load.
- The installation surface must be clean, free from floor wax and other lubricant coatings.
- Do not let the feet of the washer get wet. If the washer feet get wet, slipping may occur.